

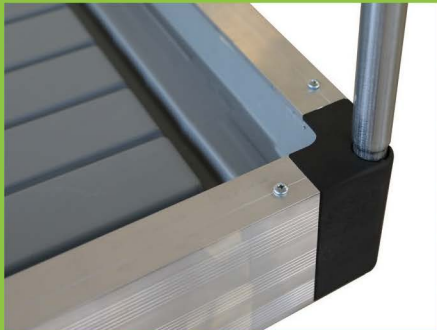

PURPOSE BUILT GREENHOUSES

Integrated Rolling Benches with Tray and Trellis

Ideal for irrigation applications and maximizing your growing space



BENCH FEATURES:

- Ebb and Flow Irrigation or Irrigation Capture
- Side-to-Side Rolling: minimize aisles and **maximize growing** (by up to 40%)
- Adjustable two-piece leg to slope and drain to one end if needed
- Designed to **withstand substantial weight** of crops
- Floor to top of table height: 17 min / 23 max
- Available in widths of 4ft, 5ft, 6ft
- Customizable lengths
- Bolt-together design allows for **economical shipping**
- Frame consists of galvanized steel and aluminum **both produced in the USA**

INTEGRATED TRELLIS DESIGN FEATURES:

- Designed for **space efficiency**, structural integrity and massive labor savings
- All steel parts
- Slots for trellis poles are built into the bench frame
- Does not involve any drilling or screws (netting not included)

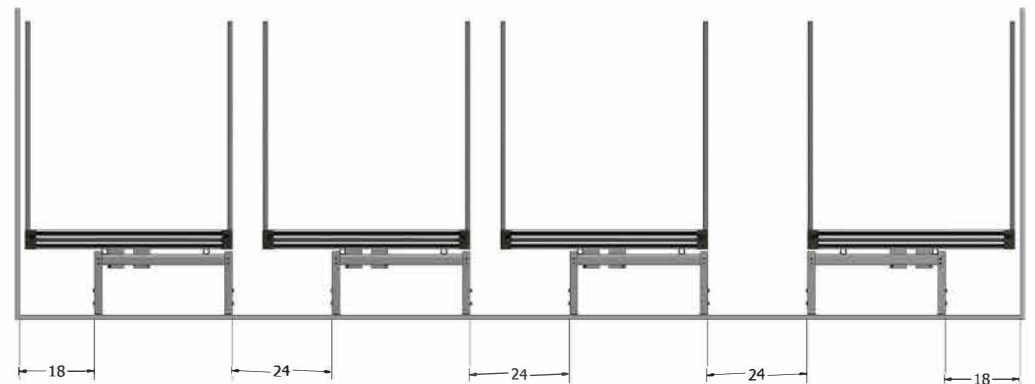

20ft room

Product Dimensions

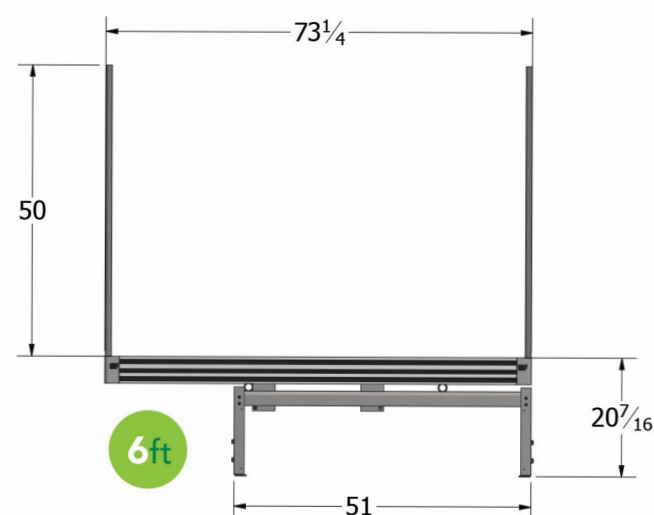
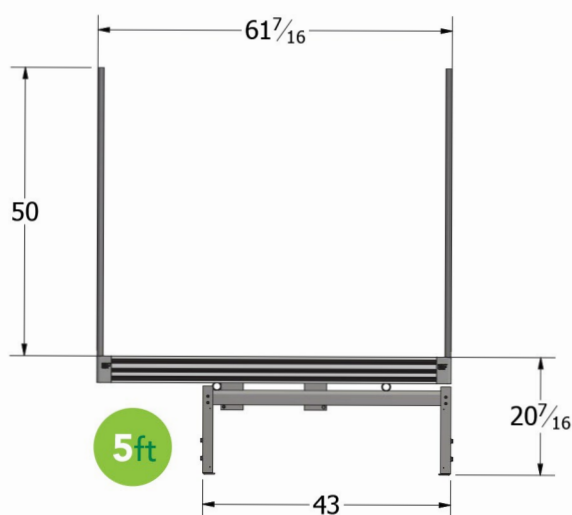
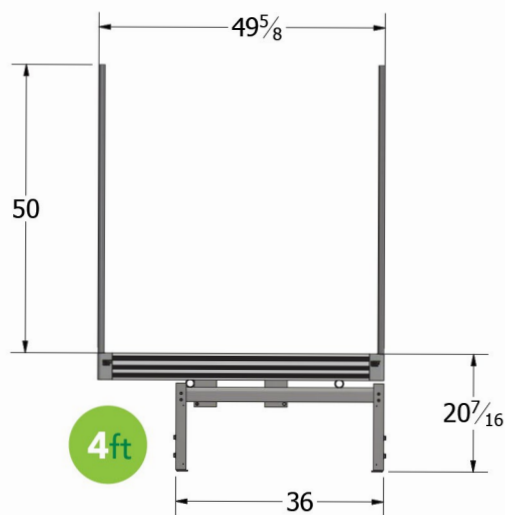
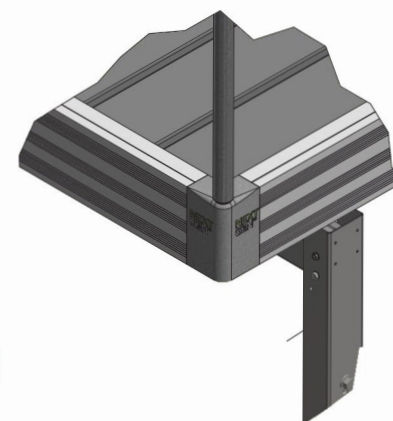
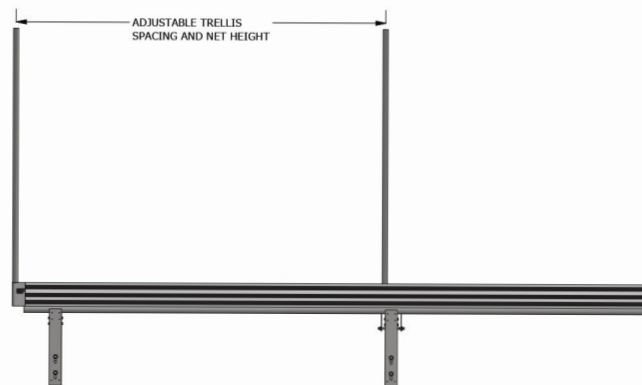
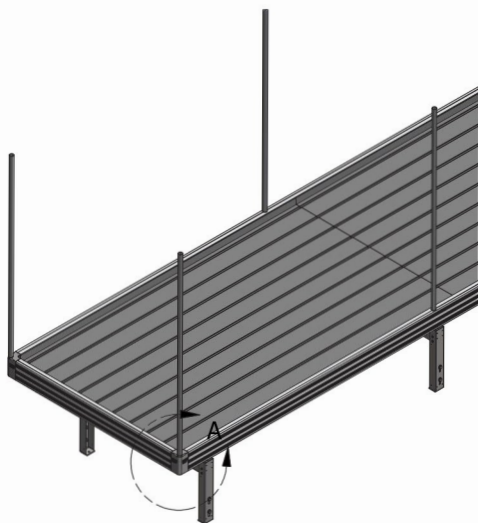

For fast quotes, please submit a quote request at

NextG3NGreenhouse.com or call **909.315.6400**

 [instagram.com/nextg3ngreenhouse](https://www.instagram.com/nextg3ngreenhouse)