

STAAL & PLAST TRAYS
***PART NUMBER AND SIZES VARY**

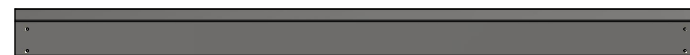

BENCH ROLL BAR
***PART NUMBER AND SIZES VARY**



BENCH CROSSBAR
***PART NUMBERS AND SIZES VARY**

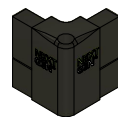

BENCH CORNER
1BEN0240



BENCH END RAIL
***PART NUMBER AND SIZES VARY**



SWAGED TRELLIS POLE
1 X 48"



BENCH SIDE RAIL
***PART NUMBER AND SIZES VARY**



TRAY SPLICE
***PART NUMBER AND SIZES VARY**



GALVANIZED ROLL TUBING
1 3/8" X 12'
LENGTHS VARY

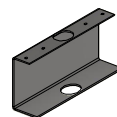

RAIL SPLICE
B0200490

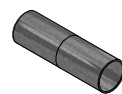

CONNECTOR SLEEVE
C9970310



STABILIZER TAB
B0200537

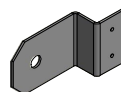

HORIZONTAL STABILIZER TAB
B0200536

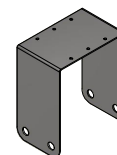

ANTI-TIP BRACKET
1BEN0515

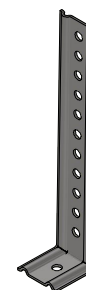

ADJUSTABLE LOWER LEG
***PART NUMBERS VARY**



ADJUSTABLE UPPER LEG
***PART NUMBERS VARY**

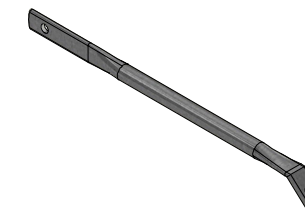

BENCH STABILIZER TUBE
B0200535



HEX TEK SCREW
10-16 X 3/4"
S9970010



PANHEAD TEK SCREW
10-16 X 3/4"
S9970015



'AB' SCREW
10-16 X 1/2"
S9970043



TEK SCREW
14-14 X 1"
S9970052



MACHINE BOLT
3/8 X 1 1/4"
B9970430



MACHINE BOLT
5/16 X 4 1/2"
B9970370



ANCHOR STUD
B9970515



3/8" FLAT WASHER
W9970240



3/8" LOCK WASHER
W9970110



3/8" HEX NUT
N9970300



5/16" HEX NUT
N9970290



This document is CONFIDENTIAL and is the property of Next G3N Greenhouse, LLC. This material shall not be used, copied or reproduced in whole or in part nor shall the contents be revealed in any manner to anyone unless written permission is obtained from Next G3N Greenhouse, LLC.

NEXT G3N™



DATE: 8/24/2020
SCALE: NTS
JOB NO:
DRAWN BY:
APPROVED:

PARTS LEGEND
TITLE:
JOB NAME:

ENGINEER:

LOADING:

DRAWING NO.:

DRAWING SET:

Sheet 1 of 13

CERTIFICATION:

4-FT BENCH

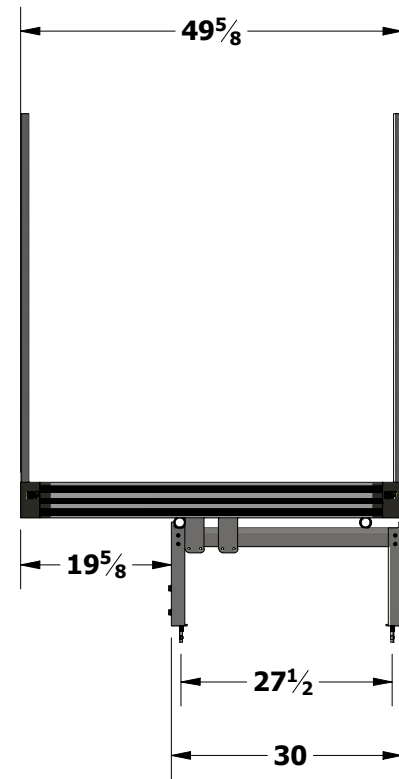

5-FT BENCH

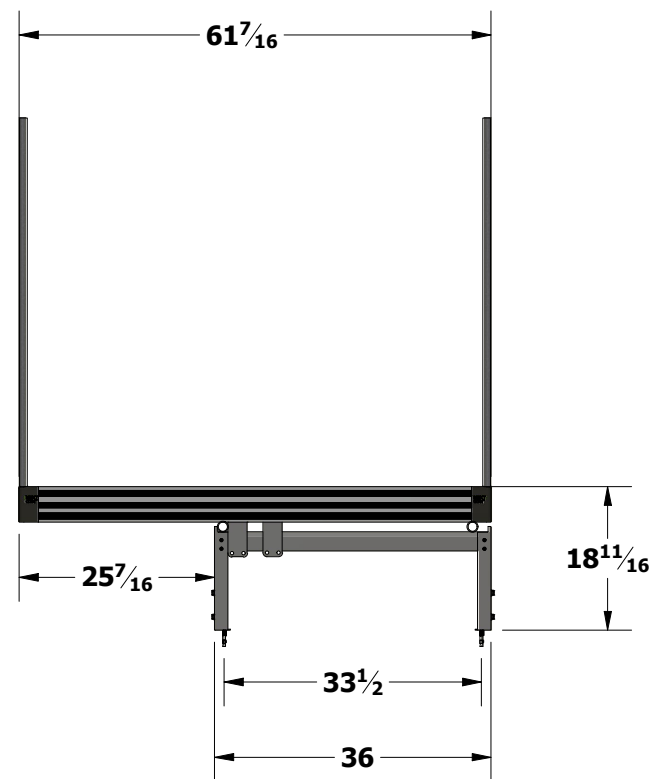

6-FT BENCH

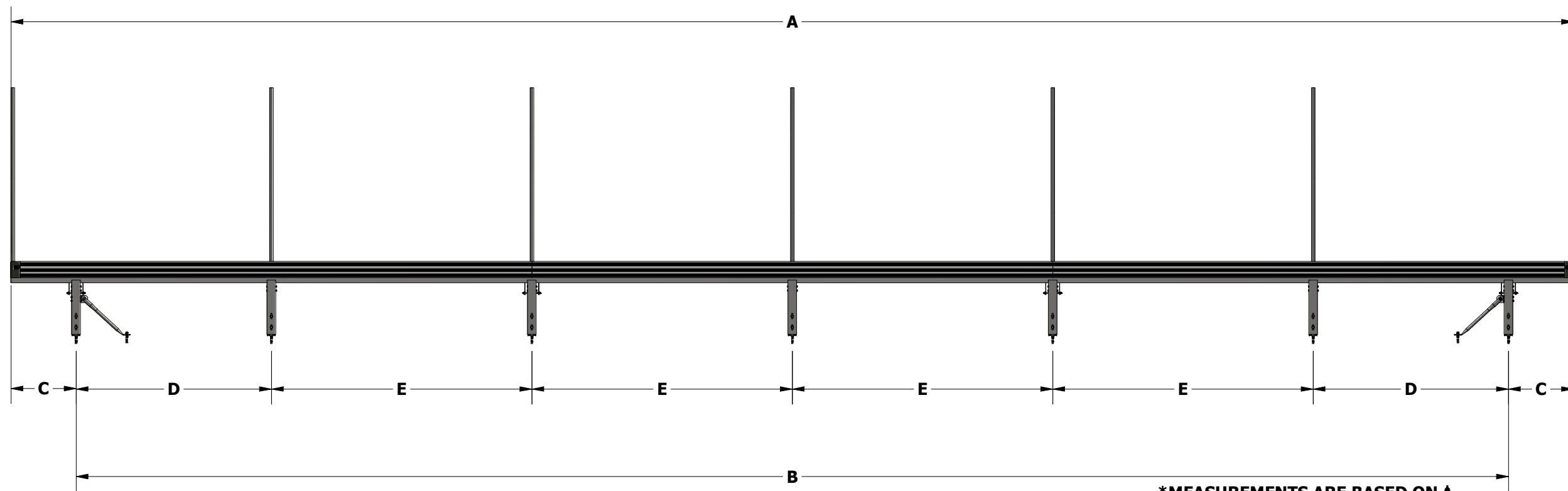
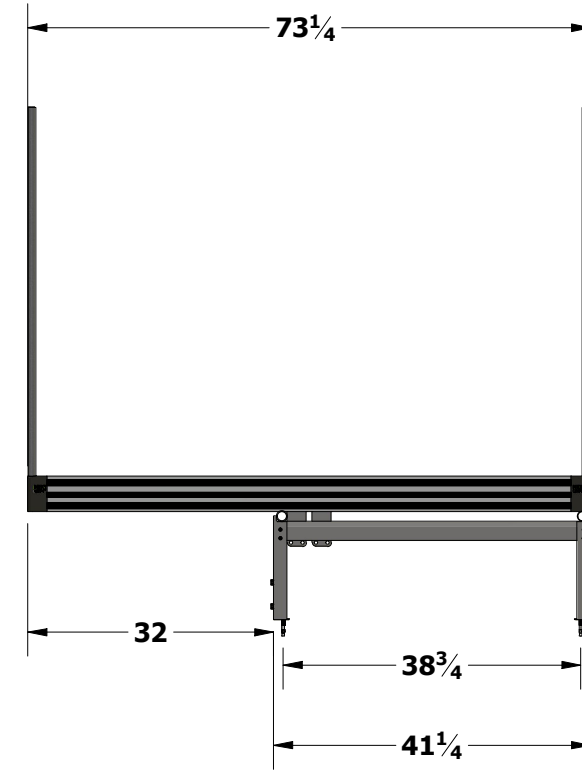

***MEASUREMENTS ARE BASED ON t
SEE LEG SPACING TABLES**



This document is CONFIDENTIAL and is the property of Next G3N Greenhouse, LLC. This material shall not be used, copied or reproduced in whole or in part nor shall the contents be revealed in any manner to anyone unless written permission is obtained from Next G3N Greenhouse, LLC.



DATE: 8/24/2020
SCALE: NTS
JOB NO:
DRAWN BY:
APPROVED:

TITLE: **LEG SPACING DIAGRAM**

ENGINEER:
LOADING:
DRAWING NO.:
DRAWING SET:

Sheet 2 of 13

CERTIFICATION



This document is CONFIDENTIAL and is the property of Next G3N Greenhouse, LLC. This material shall not be used copied or reproduced in whole or in part nor shall the contents be revealed in any manner to anyone unless written permission is obtained from Next G3N Greenhouse, LLC.

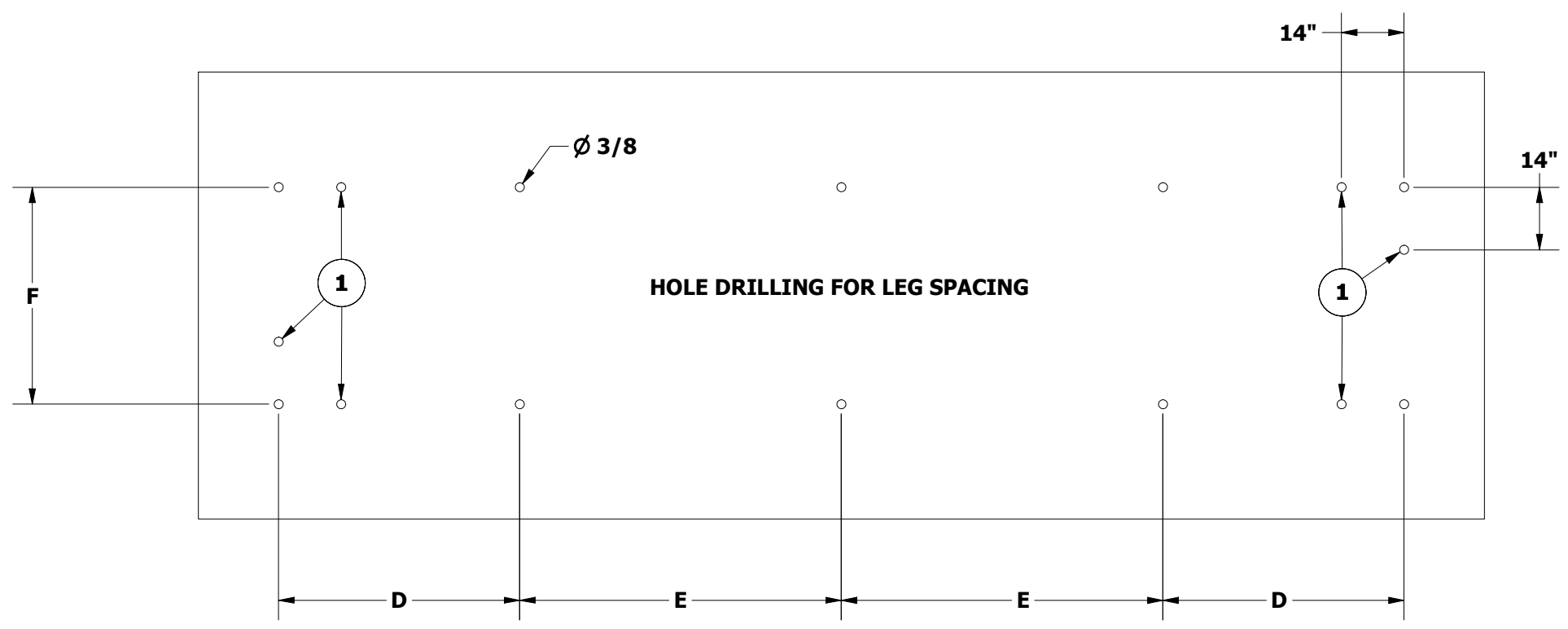

1 -ANCHOR HOLES FOR STABILIZERS

WIDTH			
	4 FT	5 FT	6 FT
F	27 1/2	33 1/2	38 3/4

SEE SUPPLEMENTAL INSTRUCTIONS FOR CROSSBAR AND ANTI-TIP INSTALLATION FOR SUMP TRAY CLEARANCE

LEG SPACING FOR BENCHES 8' TO 40'

	8'	9'	10'	11'	12'	13'	14'	15'	16'	17'	18'	19'	20'	21'	22'	23'	24'	25'	26'	27'	28'	29'	30'	31'	32'	33'	34'	35'	36'	37'	38'	39'	40'
A	96	108	120	132	144	156	168	180	192	204	216	228	240	252	264	276	288	300	312	324	336	348	360	372	384	396	408	420	432	444	456	468	480
B	72	72	108	108	108	144	144	144	180	180	180	216	216	216	252	252	252	288	288	288	324	324	324	360	360	360	396	396	396	432	432	432	468
C	12	18	6	12	18	6	12	18	6	12	18	6	12	18	6	12	18	6	12	18	6	12	18	6	12	18	6	12	18	6	12	18	6
D	72	72	54	54	54	72	72	72	54	54	54	72	72	72	54	54	54	72	72	72	54	54	54	72	72	72	54	54	54	72	72	72	54
E	N/A	N/A	N/A	N/A	N/A	N/A	N/A	N/A	72	72	72	72	72	72	72	72	72	72	72	72	72	72	72	72	72	72	72	72	72	72	72	72	72

LEG SPACING FOR BENCHES 41' TO 72'

	41'	42'	43'	44'	45'	46'	47'	48'	49'	50'	51'	52'	53'	54'	55'	56'	57'	58'	59'	60'	61'	62'	63'	64'	65'	66'	67'	68'	69'	70'	71'	72'
A	492	504	516	528	540	552	564	576	588	600	612	624	636	648	660	672	684	696	708	720	732	744	756	768	780	792	804	816	828	840	852	864
B	468	468	504	504	504	540	540	540	576	576	612	612	612	648	648	648	684	684	684	720	720	720	756	756	756	792	792	792	828	828	828	828
C	12	18	6	12	18	6	12	18	6	12	18	6	12	18	6	12	18	6	12	18	6	12	18	6	12	18	6	12	18	6	12	18
D	54	54	72	72	72	54	54	54	72	72	72	54	54	54	72	72	72	54	54	54	72	72	72	54	54	54	72	72	72	54	54	54
E	72	72	72	72	72	72	72	72	72	72	72	72	72	72	72	72	72	72	72	72	72	72	72	72	72	72	72	72	72	72	72	72

LEG SPACING FOR BENCHES 73' TO 99'

	73'	74'	75'	76'	77'	78'	79'	80'	81'	82'	83'	84'	85'	86'	87'	88'	89'	90'	91'	92'	93'	94'	95'	96'	97'	98'	99'
A	876	888	900	912	924	936	948	960	972	984	996	1008	1020	1032	1044	1056	1068	1080	1092	1104	1116	1128	1140	1152	1164	1176	1188
B	864	864	864	900	900	900	936	936	936	972	972	972	1008	1008	1008	1044	1044	1044	1080	1080	1080	1116	1116	1116	1152	1152	1152
C	6	12	18	6	12	18	6	12	18	6	12	18	6	12	18	6	12	18	6	12	18	6	12	18	6	12	18
D	72	72	72	54	54	54	72	72	72	54	54	54	72	72	72	54	54	54	72	72	72	54	54	54	72	72	72
E	72	72	72	72	72	72	72	72	72	72	72	72	72	72	72	72	72	72	72	72	72	72	72	72	72	72	72

***ADD 3 INCHES TO "C" FOR HALF SIZES

DATE: 8/24/2020
 SCALE: NTS
 JOB NO:
 DRAWN BY:
 APPROVED:

TITLE: LEG SPACING TABLES
 ENGINEER:
 LOADING:
 DRAWING NO.:
 DRAWING SET:
 Sheet 3 of 13

CERTIFICATION



This document is CONFIDENTIAL and is the property of Next G3N Greenhouse, LLC. This material shall not be used copied or reproduced in whole or in part nor shall the contents be revealed in any manner to anyone unless written permission is obtained from Next G3N Greenhouse, LLC.

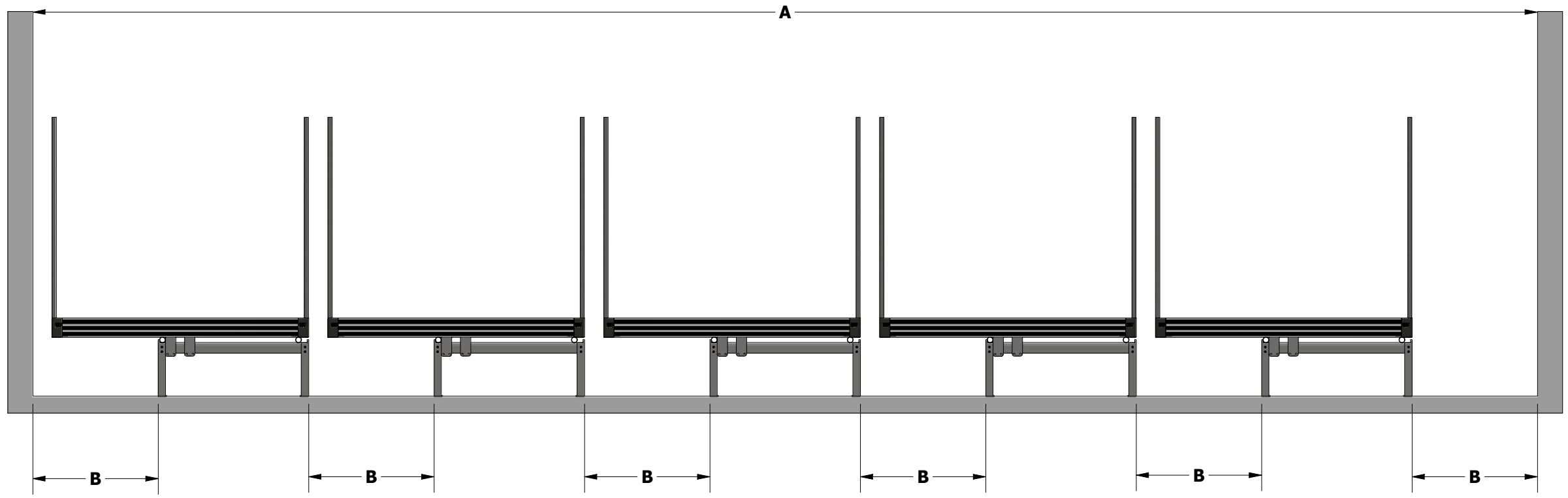

4FT BENCH AISLE SPACING

BENCHES	3	3	3	3	4	4	4	4	5	5	5	5	6	6	6	6	7	7	7	7	8	8	8	8	9	9	9	9	10	10	10	10	10	11	11	11
A	15'	16'	17'	18'	19'	20'	21'	22'	23'	24'	25'	26'	27'	28'	29'	30'	31'	32'	33'	34'	35'	36'	37'	38'	39'	40'	41'	42'	43'	44'	45'	46'	47'	48'	49'	50'
B	22 1/2	25 1/2	28 1/2	31 1/2	21 5/8	24	26 3/8	28 13/16	21	23	25	27	20 9/16	22 5/16	24	25 11/16	20 1/4	21 3/4	23 1/4	24 3/4	20	21 5/16	22 11/16	24	19 13/16	21	22 3/16	23 3/8	19 5/8	20 3/4	21 13/16	22 15/16	24	20 1/2	21 1/2	22 1/2

5 FT BENCH AISLE SPACING

BENCHES	2	2	2	3	3	3	3	3	4	4	4	4	4	5	5	5	5	5	6	6	6	6	6	7	7	7	7	7	7	8	8	8	8	8	9	9
A	15'	16'	17'	18'	19'	20'	21'	22'	23'	24'	25'	26'	27'	28'	29'	30'	31'	32'	33'	34'	35'	36'	37'	38'	39'	40'	41'	42'	43'	44'	45'	46'	47'	48'	49'	50'
B	36	40	44	27	30	33	36	39	26 3/8	28 13/16	31 3/16	33 5/8	36	26	28	30	32	34	25 11/16	27 7/16	29 1/8	30 7/8	32 9/16	25 1/2	27	28 1/2	30	31 1/2	33	26 11/16	28	29 5/16	30 11/16	32	26 3/8	27 5/8

6 FT BENCH AISLE SPACING

BENCHES	2	2	2	2	3	3	3	3	3	3	3	4	4	4	4	4	4	5	5	5	5	5	5	6	6	6	6	6	6	7	7	7	7	7	7
A	17'	18'	19'	20'	21'	22'	23'	24'	25'	26'	27'	28'	29'	30'	31'	32'	33'	34'	35'	36'	37'	38'	39'	40'	41'	42'	43'	44'	45'	46'	47'	48'	49'	50'	
B	40 1/2	44 1/2	48 1/2	52 1/2	32 1/16	35 1/16	38 1/16	41 1/16	44 1/16	47 1/16	50 1/16	34 3/16	36 5/8	39	41 3/8	43 13/16	46 3/16	33 5/8	35 5/8	37 5/8	39 5/8	41 5/8	43 5/8	33 3/16	34 15/16	36 5/8	38 3/8	40 1/16	41 13/16	32 15/16	34 7/16	35 15/16	37 7/16	38 15/16	

*****REFERENCE FOR EVENLY SPACED AISLES
AISLE SPACING CAN BE DECIDED BY INSTALLER**

DATE: 8/24/2020
 SCALE: NTS
 JOB NO:
 DRAWN BY:
 APPROVED:
 TITLE: AISLE SPACING
 ENGINEER:
 LOADING:
 DRAWING NO.:
 DRAWING SET:
 Sheet 4 of 13
 CERTIFICATION:



This document is CONFIDENTIAL and is the property of Next G3N Greenhouse, LLC. This material shall not be used copied or reproduced in whole or in part nor shall the contents be revealed in any manner to anyone unless written permission is obtained from Next G3N Greenhouse, LLC.



DATE: 8/24/2020
 SCALE: NTS
 JOB NO:
 DRAWN BY:
 APPROVED:

TITLE: LEG ASSEMBLY

ENGINEER:

LOADING:

DRAWING NO.:

DRAWING SET:

Sheet 5 of 13

CERTIFICATION:

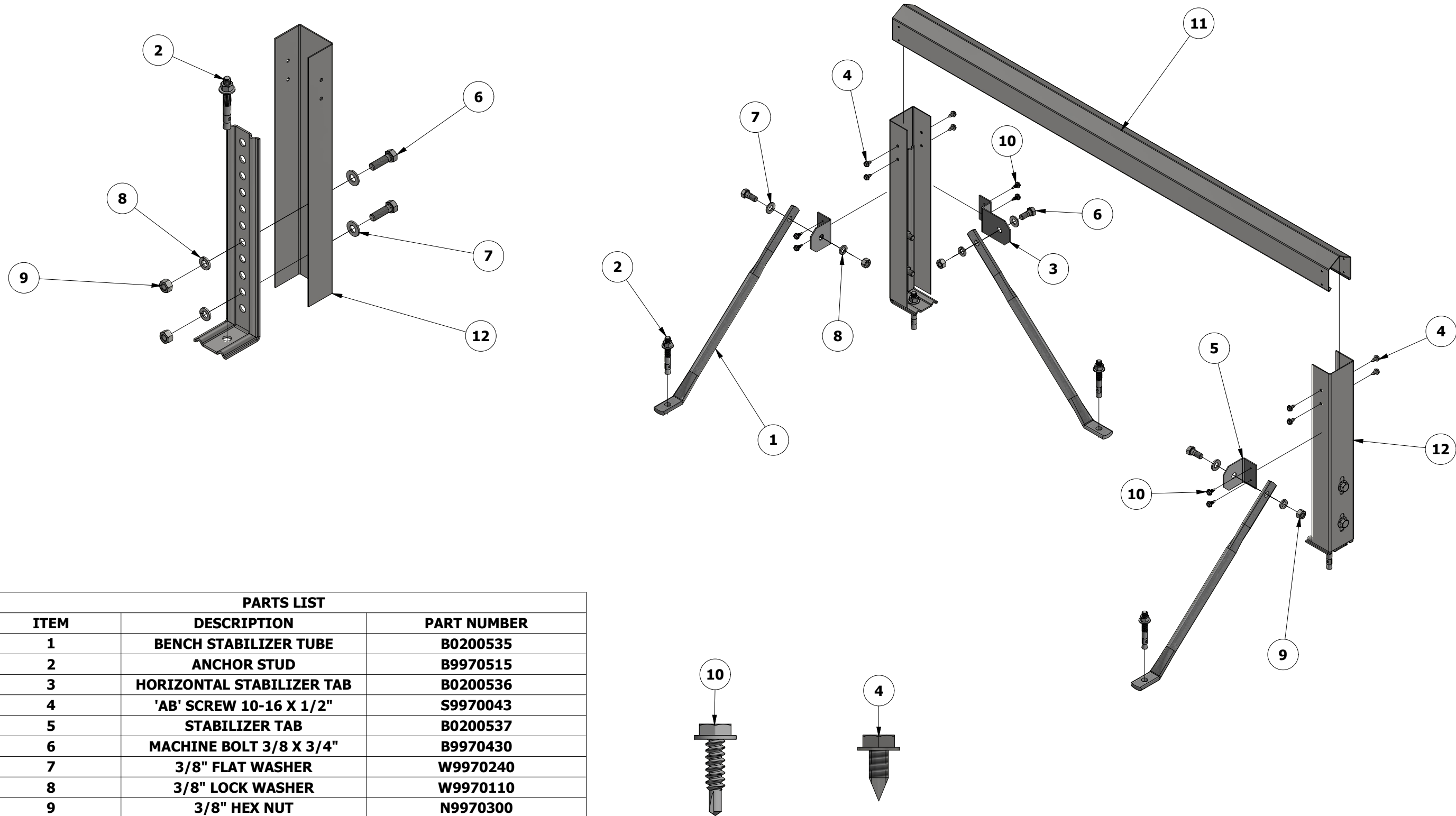

PARTS LIST		
ITEM	DESCRIPTION	PART NUMBER
1	BENCH STABILIZER TUBE	B0200535
2	ANCHOR STUD	B9970515
3	HORIZONTAL STABILIZER TAB	B0200536
4	'AB' SCREW 10-16 X 1/2"	S9970043
5	STABILIZER TAB	B0200537
6	MACHINE BOLT 3/8 X 3/4"	B9970430
7	3/8" FLAT WASHER	W9970240
8	3/8" LOCK WASHER	W9970110
9	3/8" HEX NUT	N9970300
10	HEX TEK SCREW 10-16 X 3/4"	S9970010
11	BENCH ROLL BAR	VARIES BY SIZE
12	ADJUSTABLE UPPER LEG	VARIES BY SIZE
13	ADJUSTABLE LOWER LEG	VARIES BY SIZE

***STABILIZER TUBES ARE ONLY ATTACHED ON THE ENDS OF THE BENCH
 SEE LEG SPACING DIAGRAM**

BENCHES UP TO 12'
1 SIDE RAIL SECTION

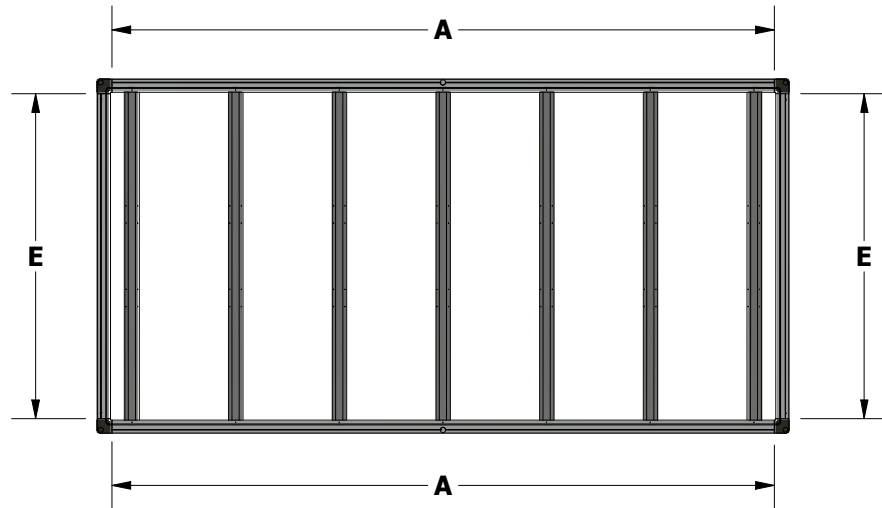

BENCHES 13' TO 24'
2 SIDE RAIL SECTIONS

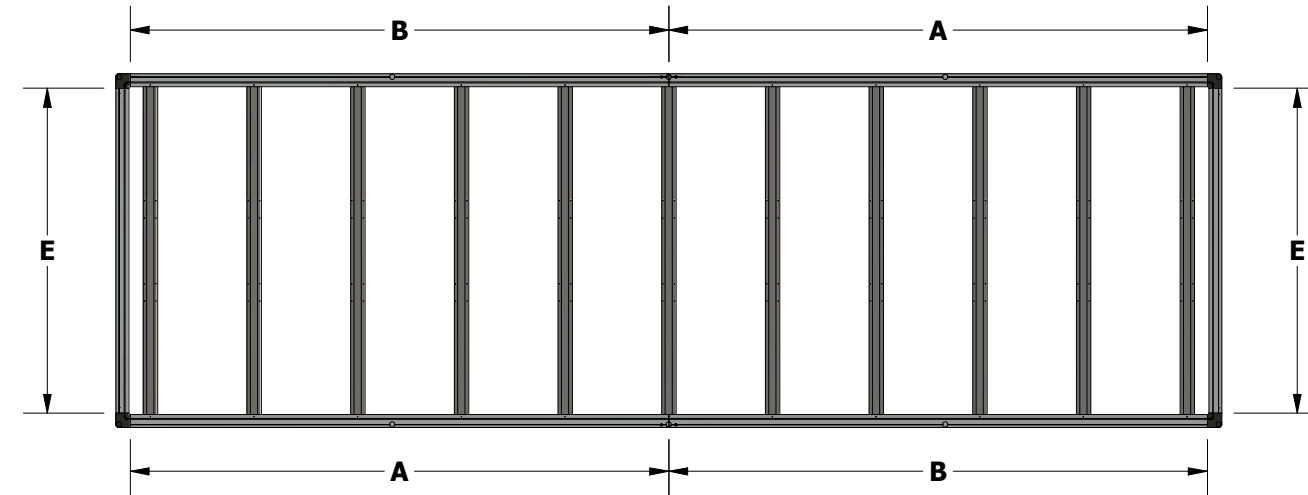

BENCHES 25' TO 36'
3 SIDE RAIL SECTIONS

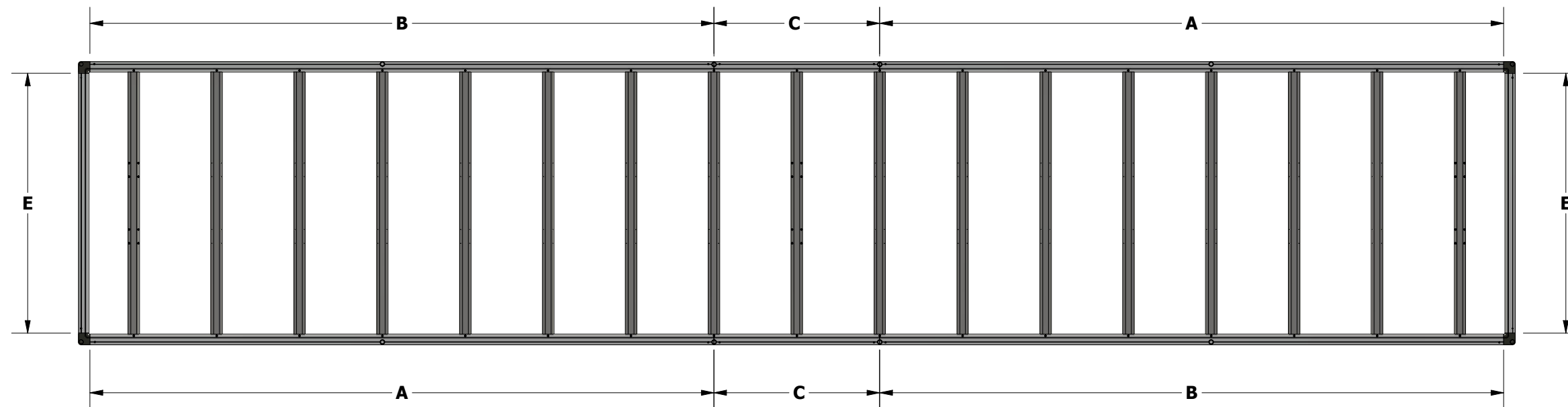

This document is CONFIDENTIAL and is the property of Next G3N Greenhouse, LLC. This material shall not be used, copied or reproduced in whole or in part nor shall the contents be revealed in any manner to anyone unless written permission is obtained from Next G3N Greenhouse, LLC.

NEXT G3N™



DATE	8/24/2020
SCALE	NTS
JOB NO	
DRAWN BY	
APPROVED	

TITLE	BENCH SIDE RAIL GUIDE
ENGINEER	
LOADING	
DRAWING NO.	
DRAWING SET	
Sheet 6 of 13	

JOB NAME	
CERTIFICATION	

BENCHES 37' TO 48'

4 SIDE RAIL SECTIONS

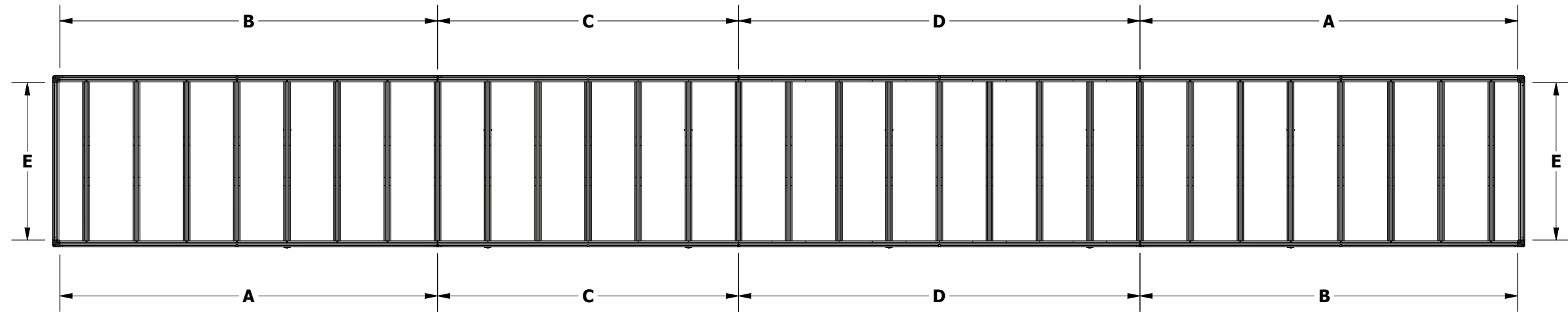

BENCHES 49' AND ABOVE

5+ SIDE RAIL SECTIONS

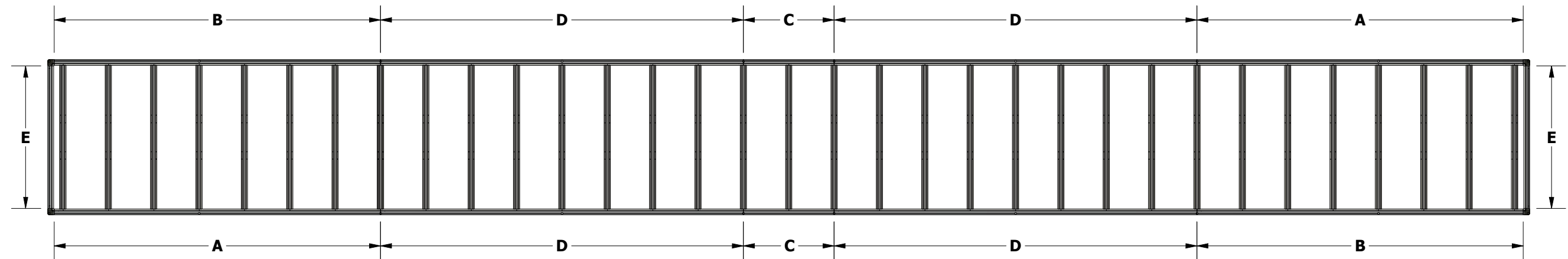

This document is CONFIDENTIAL and is the property of Next G3N Greenhouse, LLC. This material shall not be used, copied or reproduced in whole or in part nor shall the contents be revealed in any manner to anyone unless written permission is obtained from Next G3N Greenhouse, LLC.



DATE: 8/24/2020
 SCALE: NTS
 JOB NO:
 DRAWN BY:
 APPROVED:

TITLE: **BENCH SIDE RAIL GUIDE**
 ENGINEER:

LOADING

DRAWING NO.

DRAWING SET

Sheet 7 of 13

CERTIFICATION



This document is CONFIDENTIAL and is the property of Next G3N Greenhouse, LLC. This material shall not be used, copied or reproduced in whole or in part nor shall the contents be revealed in any manner to anyone unless written permission is obtained from Next G3N Greenhouse, LLC.



DATE: 8/24/2020
 SCALE: NTS
 JOB NO:
 DRAWN BY:
 APPROVED:

TITLE: BENCH RAIL TABLES
 JOB NAME:

LOADING

DRAWING NO.

DRAWING SET

Sheet 8 of 13

CERTIFICATION

8' - 25' BENCH SIDE RAILS

	8'	9'	10'	11'	12'	13'	14'	15'	16'	17'	18'	19'	20'	21'	22'	23'	24'	25'
A	1BEN0025	1BEN0030	1BEN0035	1BEN0040	1BEN0045	1BEN0050	1BEN0060	1BEN0070	1BEN0080	1BEN0090	1BEN0100	1BEN0110	1BEN0120	1BEN0130	1BEN0215	1BEN0205	1BEN0195	1BEN0215
B	N/A	N/A	N/A	N/A	N/A	1BEN0055	1BEN0065	1BEN0075	1BEN0085	1BEN0095	1BEN0105	1BEN0115	1BEN0125	1BEN0135	1BEN0220	1BEN0210	1BEN0200	1BEN0220
C	N/A	N/A	N/A	N/A	N/A	N/A	N/A	N/A	N/A	N/A	N/A	N/A	N/A	N/A	N/A	N/A	N/A	1BEN0190

26' - 43' BENCH SIDE RAILS

	26'	27'	28'	29'	30'	31'	32'	33'	34'	35'	36'	37'	38'	39'	40'	41'	42'	43'
A	1BEN0205	1BEN0195	1BEN0215	1BEN0205	1BEN0195	1BEN0215	1BEN0205	1BEN0195	1BEN0215	1BEN0205	1BEN0195	1BEN0215	1BEN0205	1BEN0195	1BEN0215	1BEN0205	1BEN0195	1BEN0215
B	1BEN0210	1BEN0200	1BEN0220	1BEN0210	1BEN0200	1BEN0220	1BEN0210	1BEN0200	1BEN0220	1BEN0210	1BEN0200	1BEN0220	1BEN0210	1BEN0200	1BEN0220	1BEN0210	1BEN0200	1BEN0220
C	1BEN0190	1BEN0190	1BEN0185	1BEN0185	1BEN0185	1BEN0180	1BEN0180	1BEN0180	1BEN0170	1BEN0170	1BEN0170	1BEN0190	1BEN0190	1BEN0190	1BEN0185	1BEN0185	1BEN0185	1BEN0180
D	N/A	N/A	N/A	N/A	N/A	N/A	N/A	N/A	N/A	N/A	N/A	1BEN0170	1BEN0170	1BEN0170	1BEN0170	1BEN0170	1BEN0170	1BEN0170

44' - 61' BENCH SIDE RAILS

	44'	45'	46'	47'	48'	49'	50'	51'	52'	53'	54'	55'	56'	57'	58'	59'	60'	61'
A	1BEN0205	1BEN0195	1BEN0215	1BEN0205	1BEN0195	1BEN0215	1BEN0205	1BEN0195	1BEN0215	1BEN0205	1BEN0195	1BEN0215	1BEN0205	1BEN0195	1BEN0215	1BEN0205	1BEN0195	1BEN0215
B	1BEN0210	1BEN0200	1BEN0220	1BEN0210	1BEN0200	1BEN0220	1BEN0210	1BEN0200	1BEN0220	1BEN0210	1BEN0200	1BEN0220	1BEN0210	1BEN0200	1BEN0220	1BEN0210	1BEN0200	1BEN0220
C	1BEN0180	1BEN0180	N/A	N/A	N/A	1BEN0190	1BEN0190	1BEN0190	1BEN0185	1BEN0185	1BEN0185	1BEN0180	1BEN0180	1BEN0180	N/A	N/A	N/A	1BEN0190
D	1BEN0170	1BEN0170	1BEN0170	1BEN0170	1BEN0170	1BEN0170	1BEN0170	1BEN0170	1BEN0170	1BEN0170	1BEN0170	1BEN0170	1BEN0170	1BEN0170	1BEN0170	1BEN0170	1BEN0170	1BEN0170

62' - 79' BENCH SIDE RAILS

	62'	63'	64'	65'	66'	67'	68'	69'	70'	71'	72'	73'	74'	75'	76'	77'	78'	79'
A	1BEN0205	1BEN0195	1BEN0215	1BEN0205	1BEN0195	1BEN0215	1BEN0205	1BEN0195	1BEN0215	1BEN0205	1BEN0195	1BEN0215	1BEN0205	1BEN0195	1BEN0215	1BEN0205	1BEN0195	1BEN0215
B	1BEN0210	1BEN0200	1BEN0220	1BEN0210	1BEN0200	1BEN0220	1BEN0210	1BEN0200	1BEN0220	1BEN0210	1BEN0200	1BEN0220	1BEN0210	1BEN0200	1BEN0220	1BEN0210	1BEN0200	1BEN0220
C	1BEN0190	1BEN0190	1BEN0185	1BEN0185	1BEN0185	1BEN0180	1BEN0180	1BEN0180	N/A	N/A	N/A	1BEN0190	1BEN0190	1BEN0190	1BEN0185	1BEN0185	1BEN0185	1BEN0180
D	1BEN0170	1BEN0170	1BEN0170	1BEN0170	1BEN0170	1BEN0170	1BEN0170	1BEN0170	1BEN0170	1BEN0170	1BEN0170	1BEN0170	1BEN0170	1BEN0170	1BEN0170	1BEN0170	1BEN0170	1BEN0170

80' - 97' BENCH SIDE RAILS

	80'	81'	82'	83'	84'	85'	86'	87'	88'	89'	90'	91'	92'	93'	94'	95'	96'	97'
A	1BEN0205	1BEN0195	1BEN0215	1BEN0205	1BEN0195	1BEN0215	1BEN0205	1BEN0195	1BEN0215	1BEN0205	1BEN0195	1BEN0215	1BEN0205	1BEN0195	1BEN0215	1BEN0205	1BEN0195	1BEN0215
B	1BEN0210	1BEN0200	1BEN0220	1BEN0210	1BEN0200	1BEN0220	1BEN0210	1BEN0200	1BEN0220	1BEN0210	1BEN0200	1BEN0220	1BEN0210	1BEN0200	1BEN0220	1BEN0210	1BEN0200	1BEN0220
C	1BEN0180	1BEN0180	N/A	N/A	N/A	1BEN0190	1BEN0190	1BEN0190	1BEN0185	1BEN0185	1BEN0185	1BEN0180	1BEN0180	1BEN0180	N/A	N/A	N/A	1BEN0190
D	1BEN0170	1BEN0170	1BEN0170	1BEN0170	1BEN0170	1BEN0170	1BEN0170	1BEN0170	1BEN0170	1BEN0170	1BEN0170	1BEN0170	1BEN0170	1BEN0170	1BEN0170	1BEN0170	1BEN0170	1BEN0170

4' - 6' BENCH END RAILS

	4-FT	5-FT	6-FT
E	1BEN0225	1BEN0230	1BEN0235

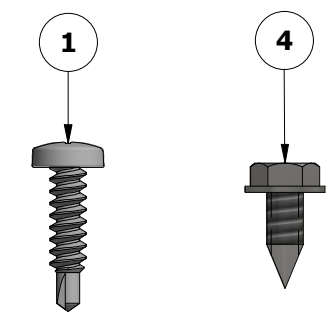
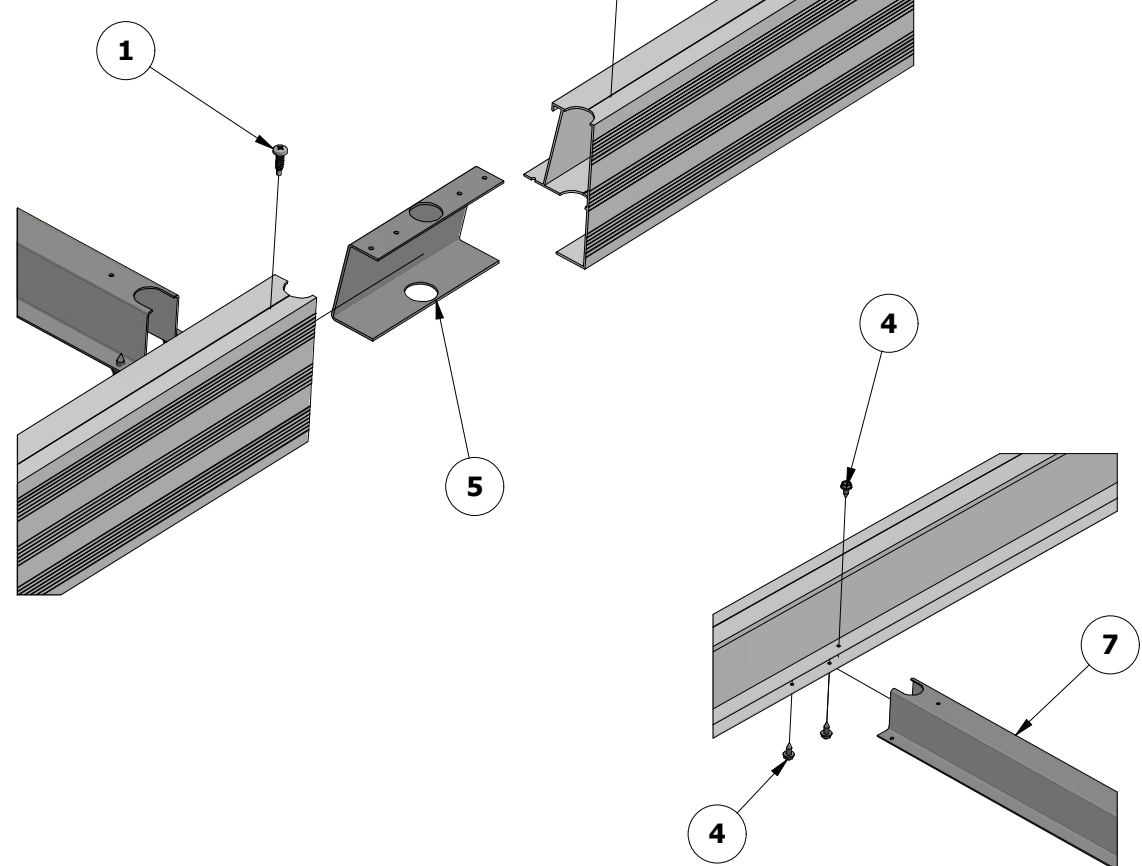
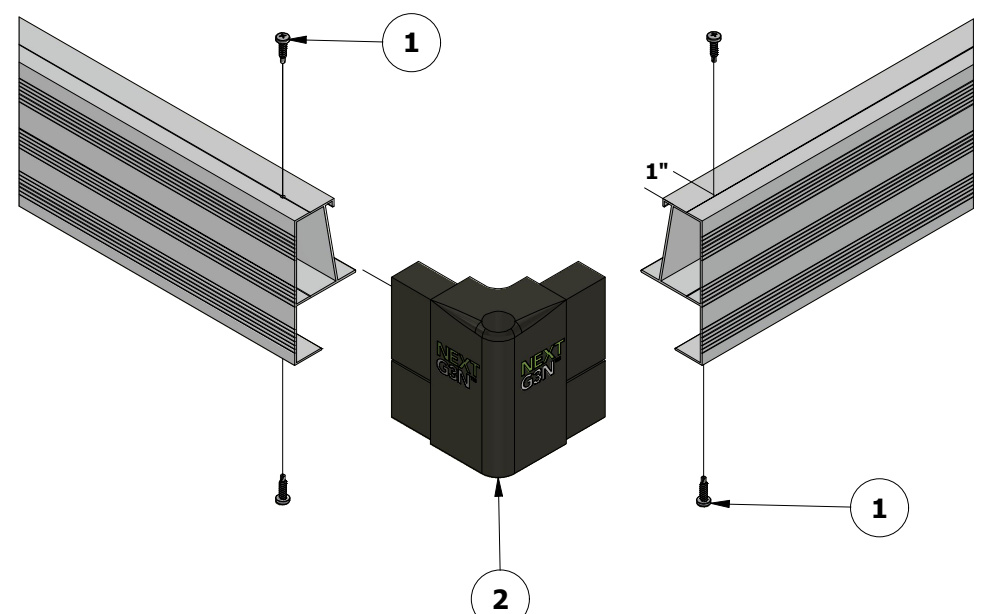
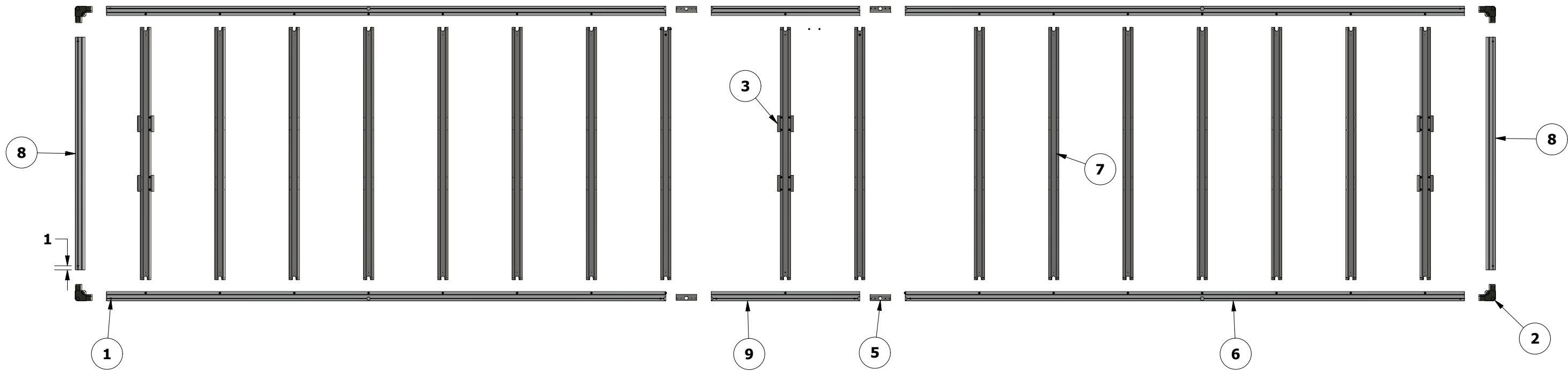

PARTS LIST

ITEM	DESCRIPTION	PART NUMBER
1	PANHEAD TEK SCREW 10-16 X 3/4"	S9970015
2	BENCH CORNER	1BEN0240
3	ANTI-TIP BRACKET	B4000602
4	'AB' SCREW 10-16 X 1-2"	S9970043
5	RAIL SPLICE	B0200490
6	BENCH SIDE RAIL END	VARIES BY SIZE
7	BENCH CROSSBAR	VARIES BY SIZE
8	BENCH END RAIL	VARIES BY SIZE
9	BENCH SIDE RAIL INTERMEDIATE	VARIES BY SIZE



This document is CONFIDENTIAL and is the property of Next G3N Greenhouse, LLC. This material shall not be used, copied or reproduced in whole or in part nor shall the contents be revealed in any manner to anyone unless written permission is obtained from Next G3N Greenhouse, LLC.



DATE: 8/24/2020
 SCALE: NTS
 JOB NO:
 DRAWN BY:
 APPROVED:

TITLE: **BENCH ASSEMBLY**
 ENGINEER:
 JOB NAME:

LOADING:
 DRAWING NO.:
 DRAWING SET:

Sheet 9 of 13

CERTIFICATION

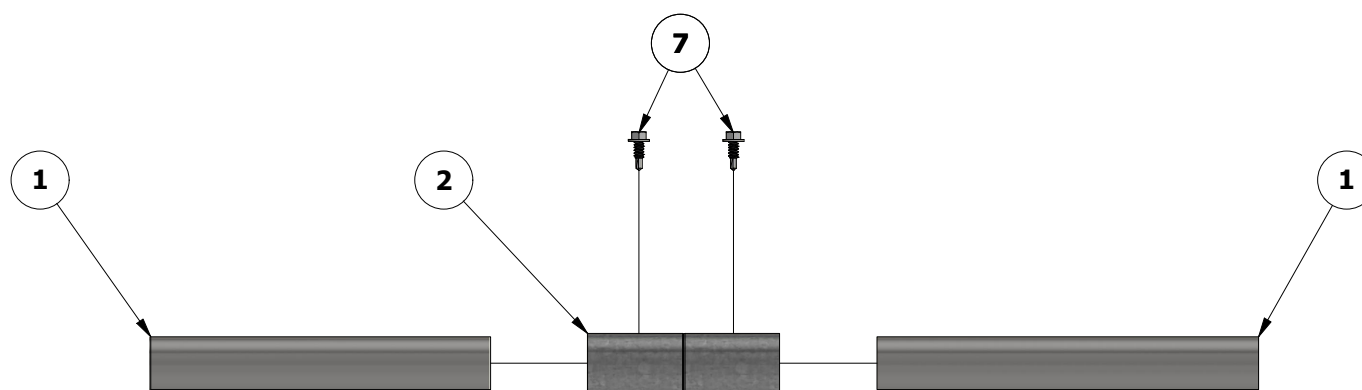
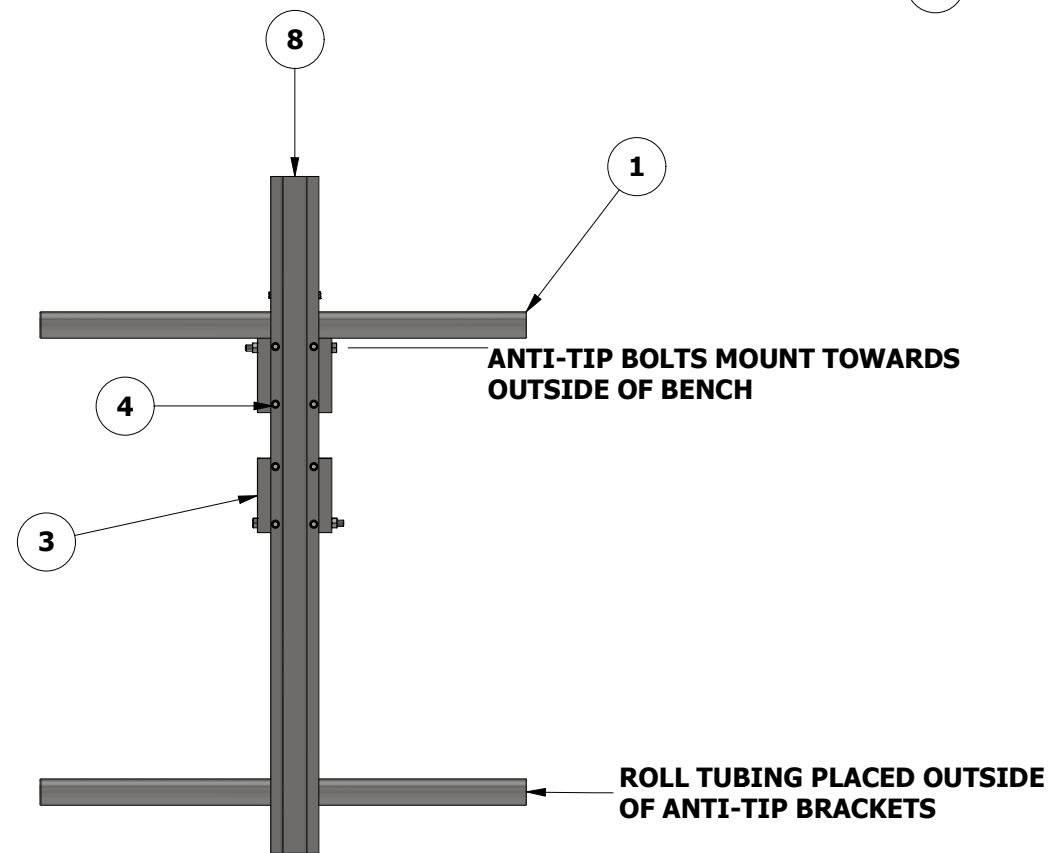
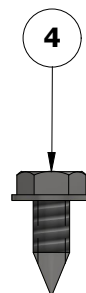
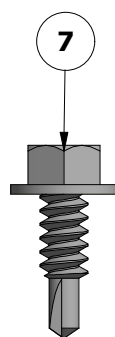
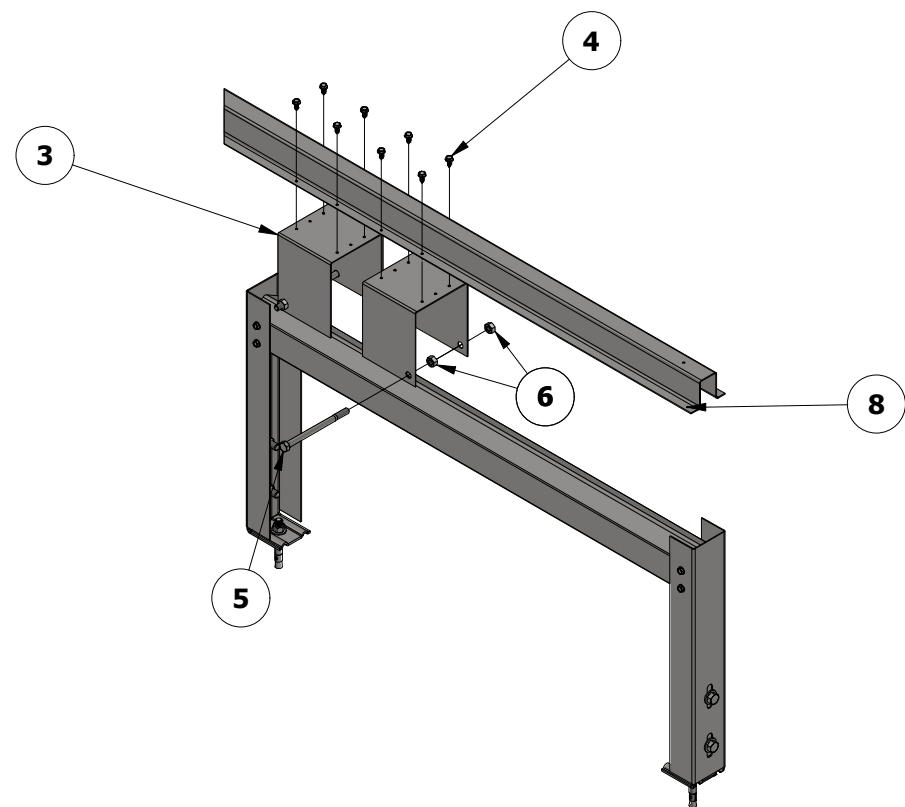
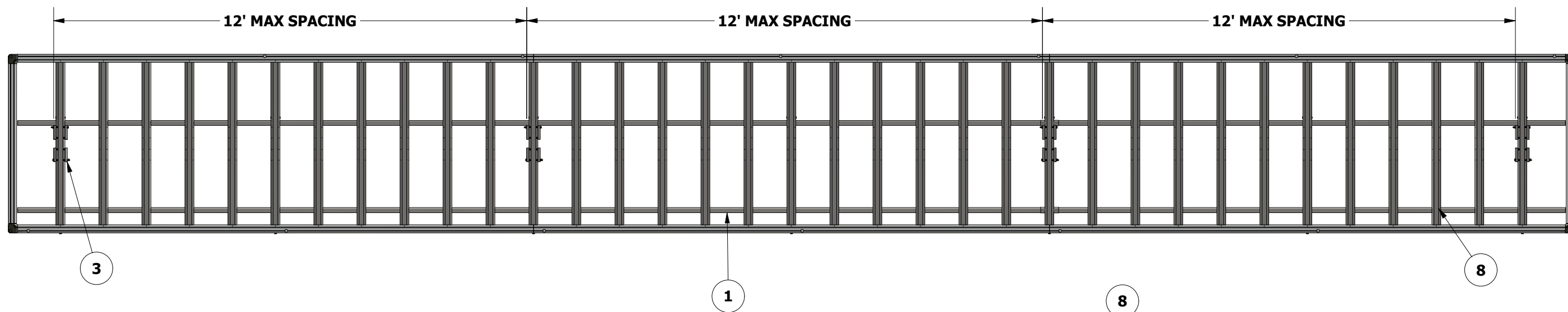

PARTS LIST		
ITEM	DESCRIPTION	PART NUMBER
1	GALVANIZED ROLL TUBING	T9970550
2	CONNECTOR SLEEVE	C9970310
3	ANTI-TIP BRACKET	B4000602
4	'AB' SCREW 10-16 X 1/2"	S9970043
5	MACHINE BOLT 5/16 X 4 1/2"	B9970370
6	5/16" HEX NUT	N9970290
7	HEX TEK SCREW 14-14 X 1"	S9970052
8	BENCH CROSSBAR	VARIABLES BY SIZE



This document is CONFIDENTIAL and is the property of Next G3N Greenhouse, LLC. This material shall not be used, copied or reproduced in whole or in part nor shall the contents be revealed in any manner to anyone unless written permission is obtained from Next G3N Greenhouse, LLC.



DATE: 8/24/2020
 SCALE: NTS
 JOB NO:
 DRAWN BY:
 APPROVED:

TITLE: ANTI-TIP ASSEMBLY
 ENGINEER:
 JOB NAME:

LOADING:
 DRAWING NO.:
 DRAWING SET:

Sheet 10 of 13

CERTIFICATION



This document is CONFIDENTIAL and is the property of Next G3N Greenhouse, LLC. This material shall not be used copied or reproduced in whole or in part nor shall the contents be revealed in any manner to anyone unless written permission is obtained from Next G3N Greenhouse, LLC.

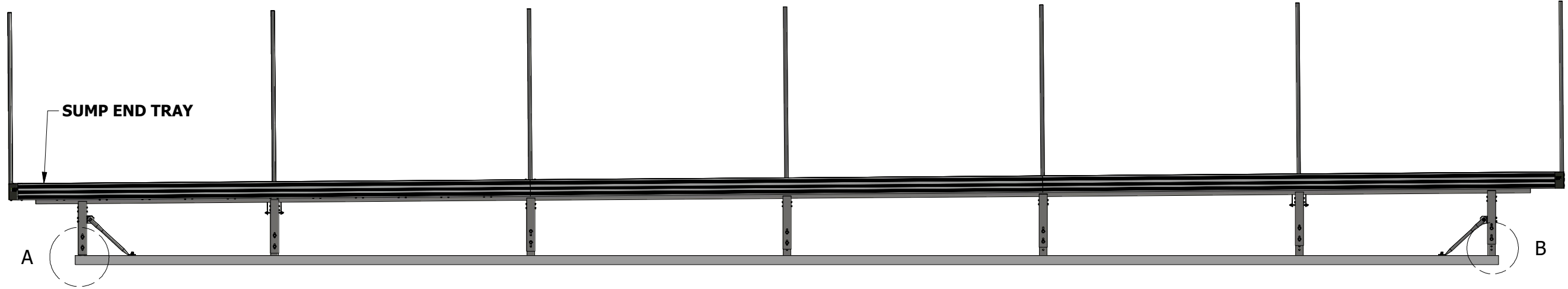

SUMP END

HIGH END

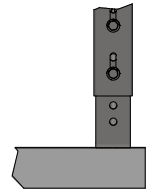
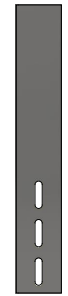
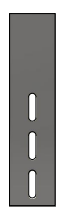
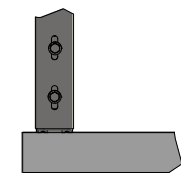

DETAIL A
SET LEG AT LOWEST LEVEL

10 IN UPPER LEG
B0200374
*5 IN MAX RISE

15 IN UPPER LEG
B0200300
*6 IN MAX RISE

DETAIL B
CHOOSE DESIRED RISE

DATE	8/24/2020
SCALE	NTS
JOB NO	
DRAWN BY	
APPROVED	

SUMP END

HIGH END

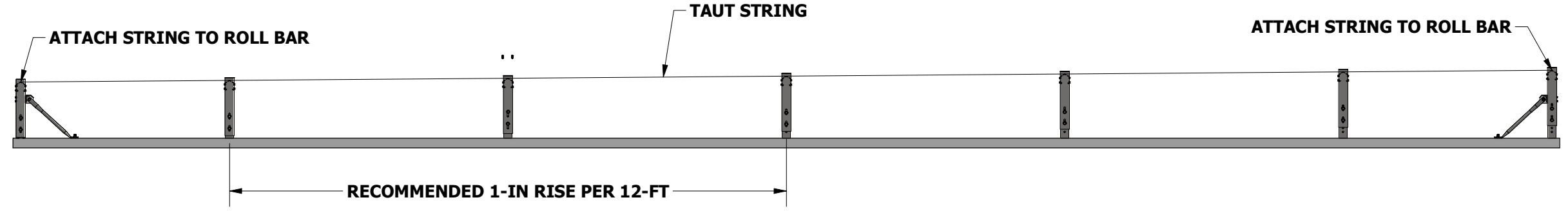

RAISE LEG HEIGHTS UNTIL
THE ROLL BARS CONTACT THE STRING

***TOO MUCH RISE CAN CAUSE THE BENCH TO SLIDE**
***TOO LITTLE RISE CAN CAUSE POOR DRAINAGE**

TITLE	SLOPE ADJUSTMENT
ENGINEER	
LOADING	
DRAWING NO.	
DRAWING SET	
Sheet 11 of 13	
CERTIFICATION	

IMPORTANT!

BENCH TRAYS EXPAND AND CONTRACT WITH A CHANGE IN TEMPERATURE. IT IS RECOMMENDED THAT INSTALLATION TAKES PLACE AT DESIRED ROOM OPERATING TEMPERATURE TO PREVENT DAMAGE TO TRAYS DUE TO THERMAL EXPANSION.

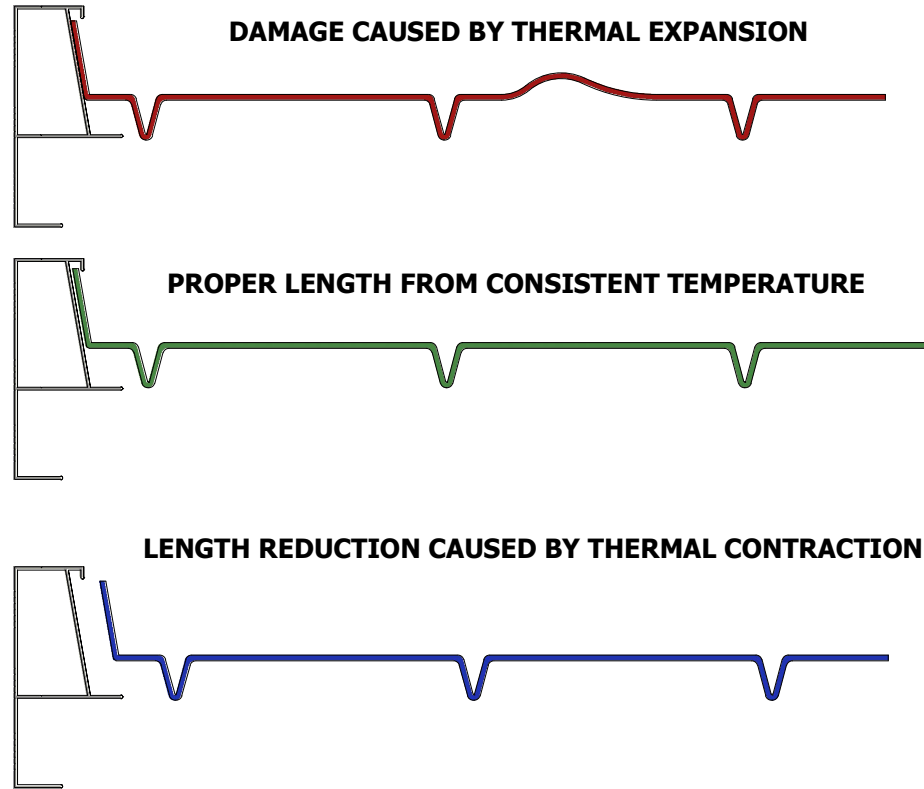

*****BE SURE TO LAY OUT ALL TRAYS WITH PROPER GAP BEFORE THE GLUE PROCESS**

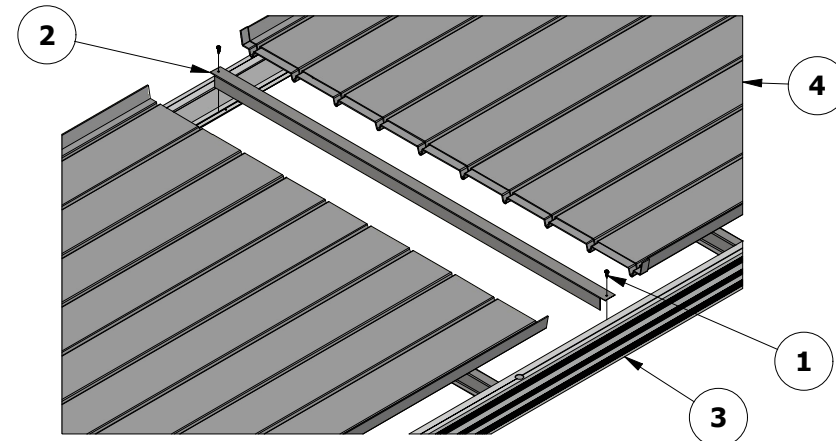

***TRAY SPLICE SUPPORTS THE FLANGE OF TRAY AT SEAMS**

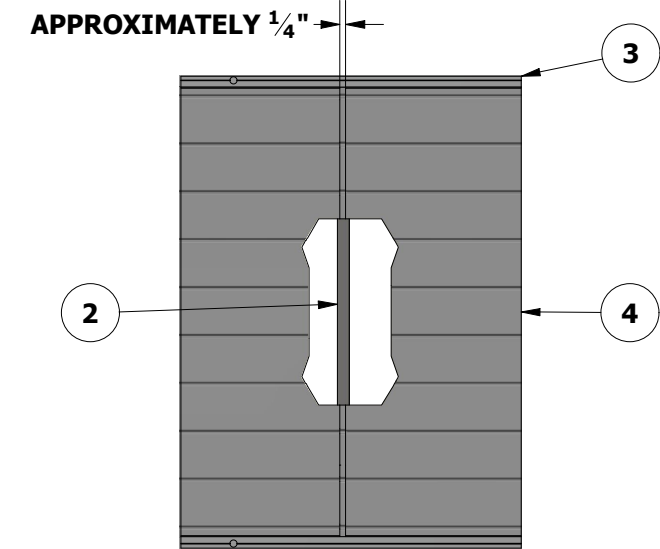

***ADD TRAY SPICE AT EACH TRAY SEAM UNLESS SEAM FALLS OVER CROSSBAR**

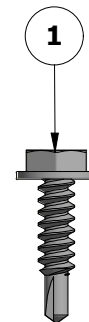
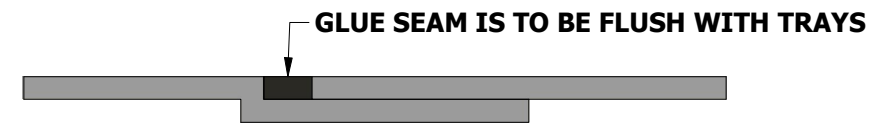
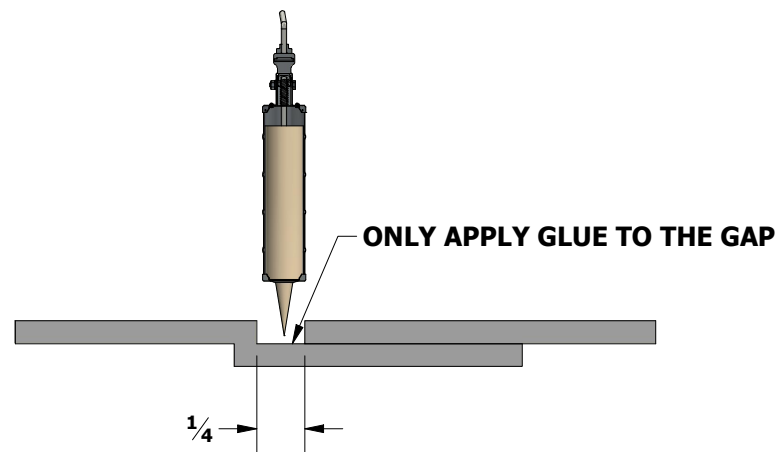
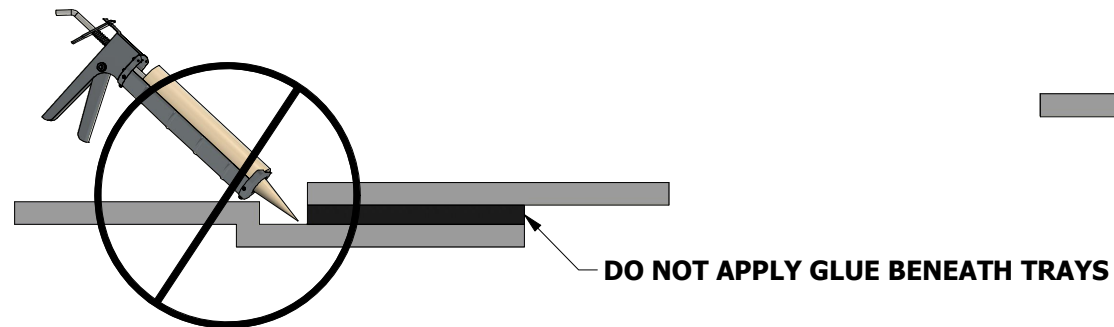

PARTS LIST		
ITEM	DESCRIPTION	PART NUMBER
1	HEX TEK SCREW 10-16 X 3/4"	S9970010
2	TRAY SPLICE	VARIES BY SIZE
3	BENCH SIDE RAIL	VARIES BY SIZE
4	STAAL & PLAST TRAY	VARIES BY SIZE
5	POLYSTYRENE GLUE	N/A



This document is CONFIDENTIAL and is the property of Next G3N Greenhouse, LLC. This material shall not be used, copied or reproduced in whole or in part nor shall the contents be revealed in any manner to anyone unless written permission is obtained from Next G3N Greenhouse, LLC.



DATE: 8/24/2020
SCALE: NTS
JOB NO:
DRAWN BY:
APPROVED:

TITLE: TRAY INSTALLATION
ENGINEER:

LOADING:

DRAWING NO.:

DRAWING SET:

Sheet 12 of 13

CERTIFICATION



MOVE CROSSBAR AWAY FROM ENDRAIL TO ALLOW ROOM FOR SUMP TRAY

ATTACH ANTI-TIP BRACKET TO CROSSBAR OVER THE SECOND LEG SET

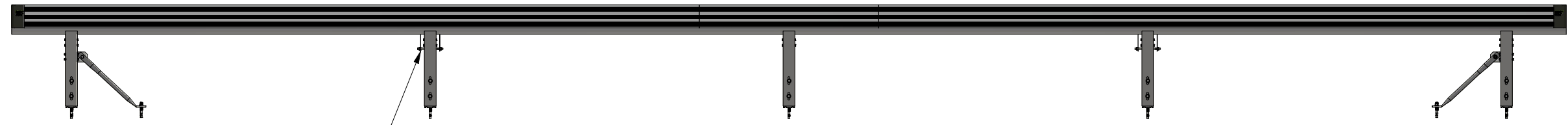

RELOCATE ANTI-TIP BRACKET TO THE SECOND LEG SET



This document is CONFIDENTIAL and is the property of Next G3N Greenhouse, LLC. This material shall not be used, copied or reproduced in whole or in part nor shall the contents be revealed in any manner to anyone unless written permission is obtained from Next G3N Greenhouse, LLC.



DATE	8/24/2020
SCALE	NTS
JOB NO.	
DRAWN BY	
APPROVED	

TITLE	SUPPLEMENTAL INSTRUCTION
ENGINEER	
LOADING	
DRAWING NO.	
DRAWING SET	
Sheet 13 of 13	

CERTIFICATION